

12" PLANER / THICKNESSER

- Combined planer thicknesser for demanding DIY enthusiasts
- **High-performance 1800 W motor** for effortless planing and thickening
- **Thickness capacity 6 – 160 mm, throat 305 mm**
- Two high-speed steel planer knives, blade speed of 9500 rpm for smooth and precise planing
- Easy height adjustment of the thickening table using hand crank
- **Planer fence with 45° angle adjustment for precise angles of 90° to 135°**
- **Planing table 1075 x 310 mm**
- **Thickening table 500 x 305 mm**
- **100 mm extraction connection**
- Vibration-absorbing rubber feet for sturdy positioning

OPTIONAL ACCESSORIES

HSS PLANER KNIVES
Two-piece set



Article number: 7902200610
Barcode: 4014915231080

2in1

- ✓ Planing
- ✓ Thickening

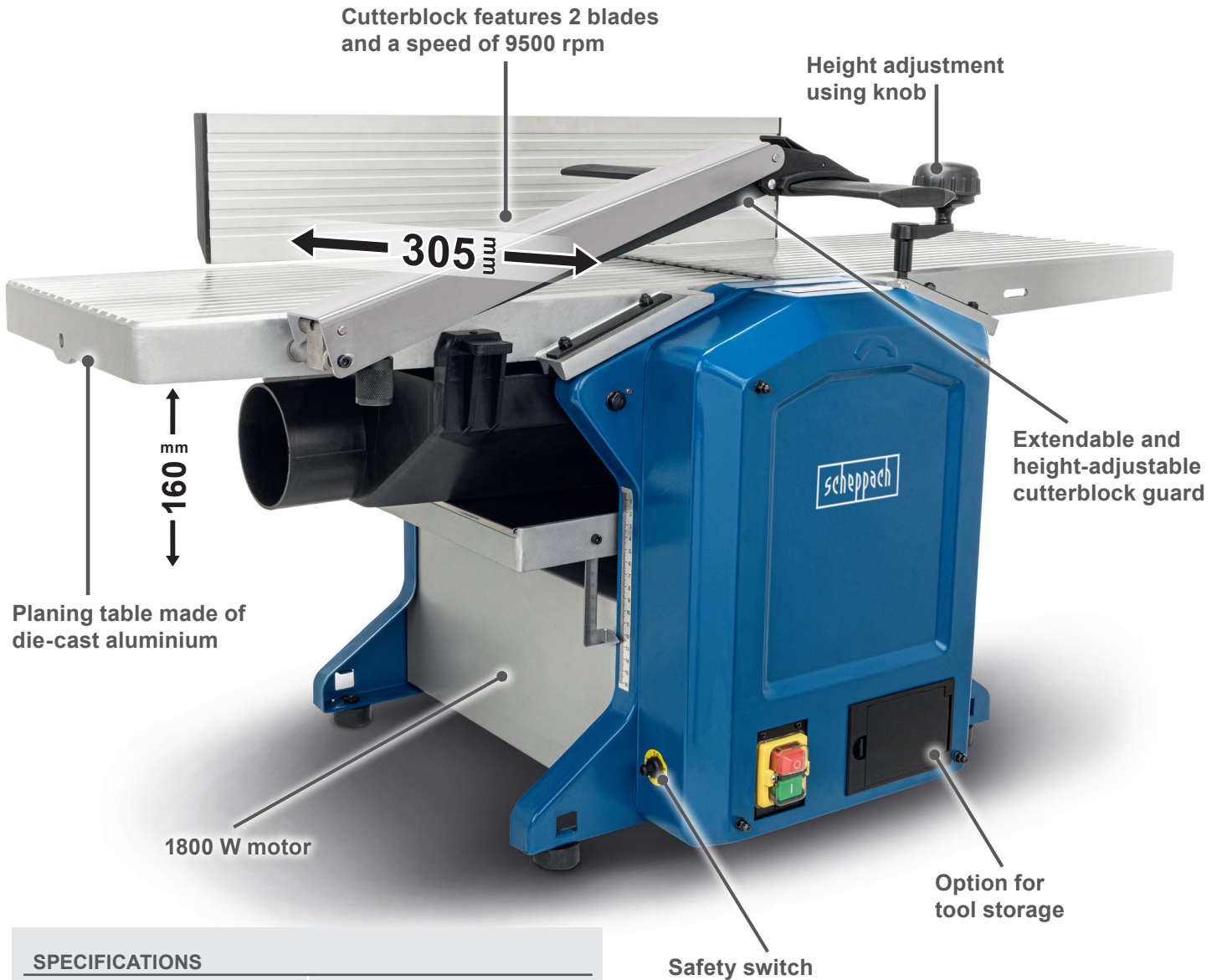
**SPECIFICATIONS**

Dimensions L x W x H	1135 x 600 x 575 mm
Surfacing table size	1075 x 310 mm
Thickening table size	500 x 305 mm
Number of blades	2
Planing shaft speed	9500 rpm

SURFACE PLANING

Plane width max.	305 mm
Stock removal max.	2 mm

THICKENING

Thickness capacity / width max.	6 - 160 mm / 305 mm
Stock removal max.	1.5 mm
Motor	230 V~
Engine power	1800 W

LOGISTICAL DATA

Weight net / gross	40 / 45 kg
Packaging dimensions	1180 x 580 x 570 mm
Article number	5902211901
Barcode	4046664140917
20 Container	116 pcs
40 Container	244 pcs
40 HQ Container	305 pcs