

MPL series "S"

MPL 65S

max. power 65 kVA

MPL 76S

max. power 76 kVA

Standard
version



Version with
Site tow



Version with
400 L Fuel tank
with retention
bund and fork
lift channels



		MPL 65S	MPL 76S
a.c. output	400 V	stand-by ⁽¹⁾	65 kVA
50 Hz. 3 ph		prime ⁽²⁾	59 kVA
power factor			0,8
fuel		Diesel	
starting		Elettrico	
alternator		Sincrono	
engine		Deutz	
type		BF4M 2011 C	BF4M 2012 C
intake		Turbo/intercooler	
cooling		Oil	Water
displacement	c.c.	3109	4038
cylinders		4	
prime power	HP	77	95,2
RPM		1500	
tank capacity	L	65	
3/4 load operating hours	h	5,5	4,5
sound power level	LwA	94	97
acoustic pressure at 7 mt.	dB(A)	69	72

⁽¹⁾ **Stand-by power:**
power available for emergency

⁽²⁾ **Prime power:** maximum power available at
variable loads for an unlimited numbers of hours

MPL 65S • MPL 76S

Standard version

MPL 65S 1160 kg
MPL 76S 1210 kg

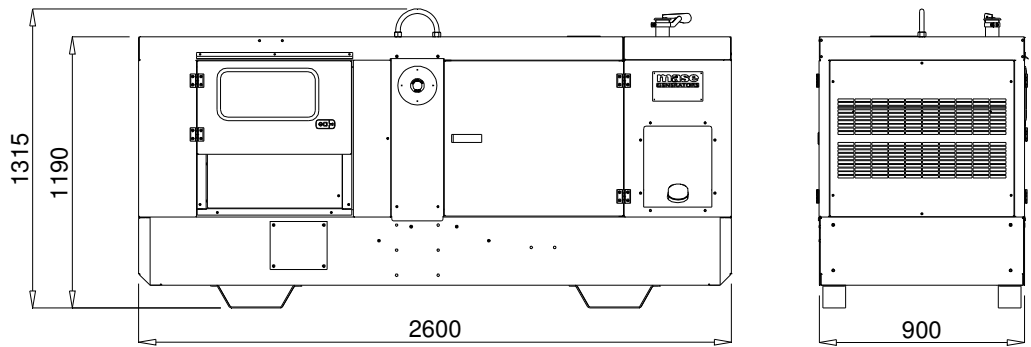

Version with 400 L fuel tank

MPL 65S 1410 kg
MPL 76S 1460 kg

3/4 load oper.hours
 34h 27h

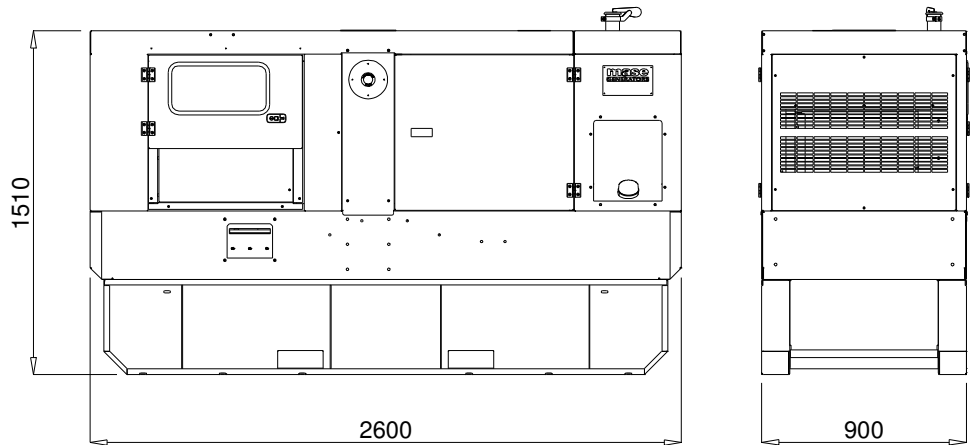

Version with Site tow

MPL 65S 1260 kg
MPL 76S 1310 kg

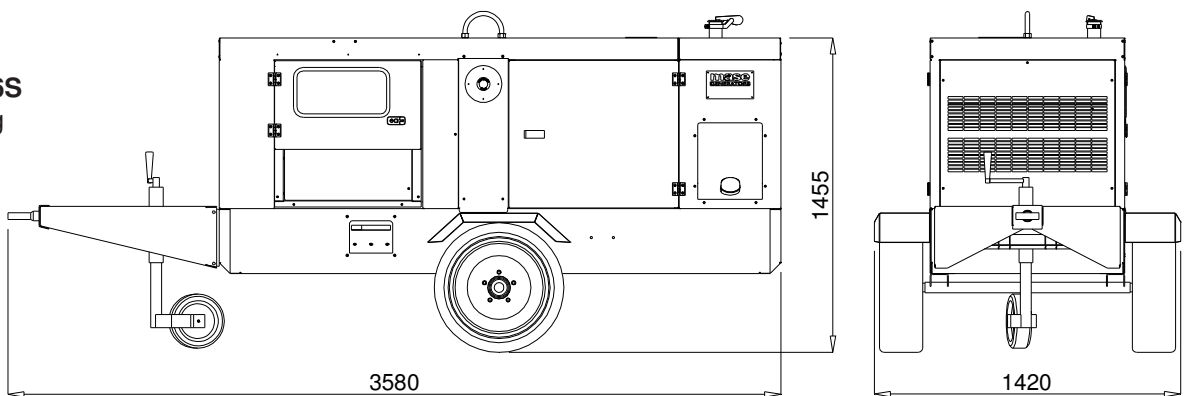

Dealer:

mase
GENERATORS

MASE GENERATORS S.p.A. Via Tortona, 345
 47522 Cesena (FC) Italy
 Tel.+39-0547-354311 Fax.+39-0547-317555
 Email : mase@masegenerators.com
 www.masegenerators.com

CONTROL PANELS

Standard manual control panel

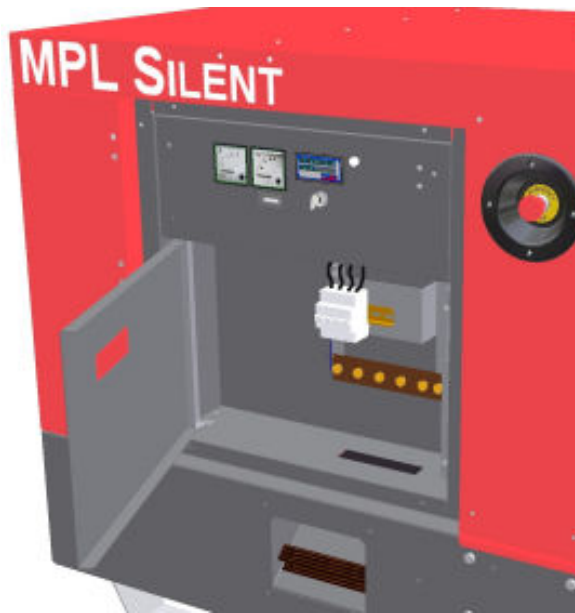

- Control panel
- Power cubicle with door

- Emergency stop button

- Power cables - terminal board
- Cover for power cables - terminal board

CONTROL PANEL

- Start/stop key
- Operation and Alarms
- Ammeter
- Voltmeter
- Hourmeter
- Fuel level gauge

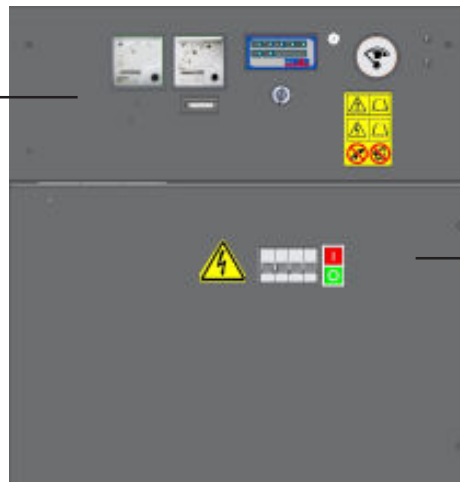

POWER CUBICLE

- Circuit breaker
- Power cables - terminal board
- Connection for remote starting panel

OPTIONAL: Sockets panel

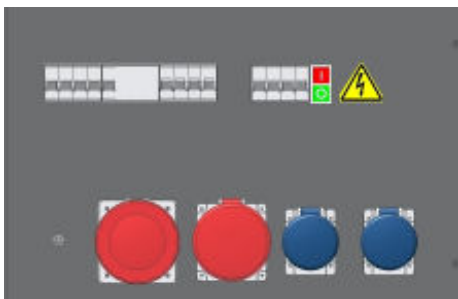

OPTIONAL : Earth fault device

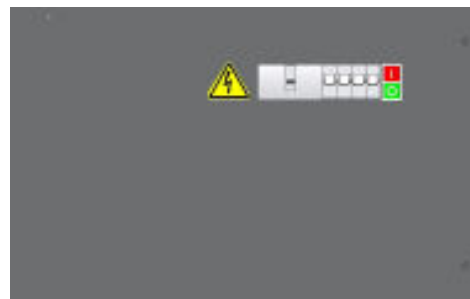

- Circuit breaker / differential protection for sockets
- No. 1 EEC socket 63 Amps. 400 V
- No. 1 EEC socket 32 Amps. 400 V
- No. 2 EEC socket 16 Amps. 230 V

OPTIONAL: Automatic starting

- Fuel level gauge

- Circuit breaker

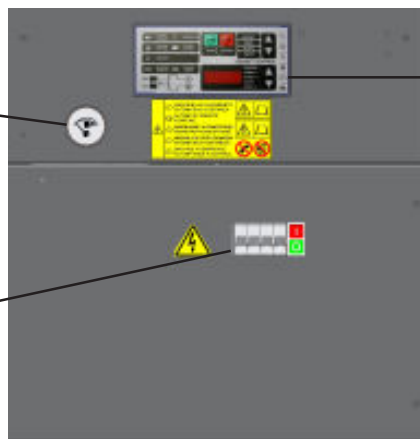

Automatic Transfer Switch in a separate box

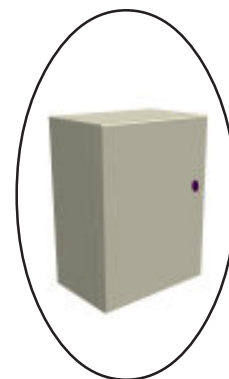

Digital Genset Control

- Automatic test
- n° 20 alarms
- n° 9 genset parameters
- n° 30 programming keys
- n° 4 operating mode

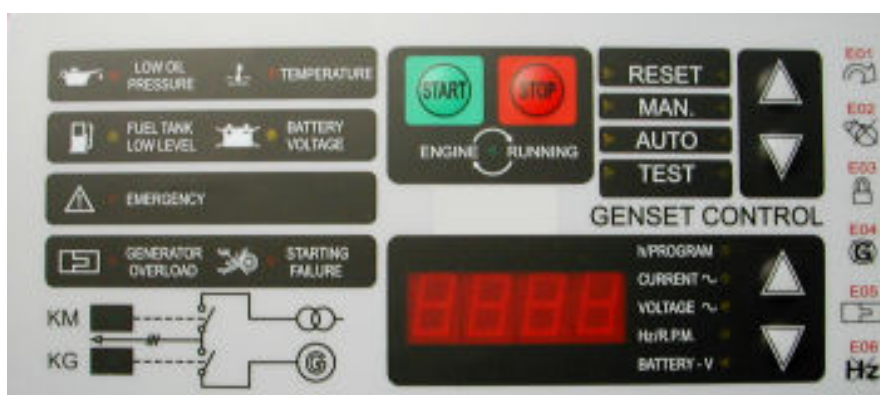

OPTIONAL :

Remote control panel with 50 mt. cable

Water heater

Automatic top-up device for on-board tank with retention bund

Dealer:

mase
GENERATORS

MASE GENERATORS S.p.A. Via Tortona, 345
47522 Cesena (FC) Italy
Tel.+39-0547-354311 Fax.+39-0547-317555
Email : mase@masegenerators.com
www.masegenerators.com