



		FX 50H/A	FX 5.4H/A
a.c. output	230 V	¹ max.kW	3,5
	50 Hz 1~	² cont.kW	3
power factor		cos ø	1
a.c. output	400 V	max .kVA	5
	50 Hz 3~	cont .kVA	4,1
power factor		cos ø	0,8
fuel starting		Gasoline electric	
alternator		synchronous	
engine		HONDA GX270	
cooling system		air	
displacement		c.c.	270
n° cylinders			1
prime power		HP	8,2
R.P.M.			3000
fuel tank capacity		lt.	6
¾ load operating hours		h	3
sound power level		L _{WA}	99
acoustic pressure at 7 mt.		dB(A)	74

		FX 50H/A	FX 5.4H/A	
DIMENSIONS	L	725	725	mm
	W	515	515	mm
	H	585	585	mm
WEIGHT		78	88	kg

⁽¹⁾ **Stand-by power:**
power available for emergency

⁽²⁾ **Prime power:** maximum power
available at variable loads for an
unlimited numbers of hours

CONTROL PANELS

FX 50 H/A

- 1 Voltmeter 300V
- 2 Remote control connector
- 3 Single-phase outlet CEE 230V 16A
- 4 Single-phase outlet CEE 230V 16A
- 5 Differential magnetothermal switch

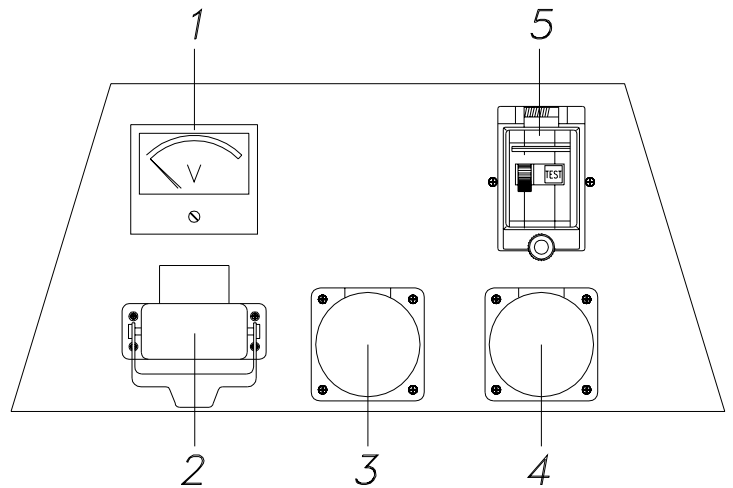

FX 5.4 H/A

- 1 Voltmeter 500V
- 2 Remote control connector
- 3 Three-phase outlet EC 400V 16A 3P+N+T
- 4 Single-phase outlet EC 230V 16A 2P+T
- 5 Differential switch 4P 25A
- 6 Magnetothermal switch 3P 6A-10A
- 7 Magnetothermal switch 1P 16A

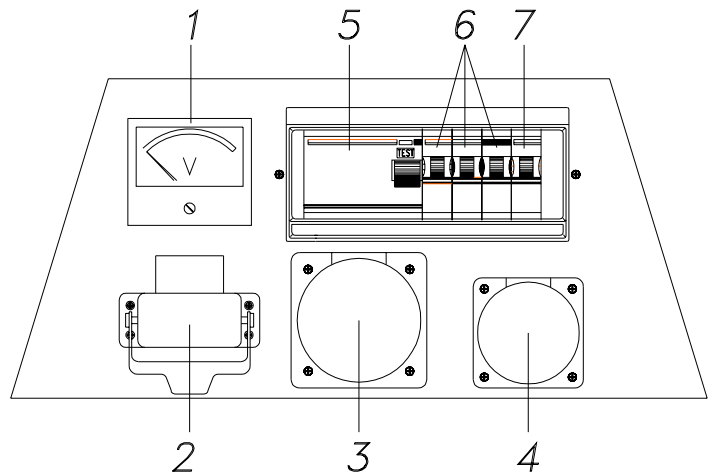

OPTIONAL

- Automatic control panel
- Remote control panel
- Undergear